

LAUNDRY

SMEG LAUNDRY APPLIANCES ARE PRODUCED WITH THE ENVIRONMENT IN MIND, USING MINIMUM AMOUNTS OF WATER AND ELECTRICITY TO KEEP RUNNING COSTS LOW. THE FRONT PANEL CAN BE REMOVED, ENSURING EASY ACCESS TO ALL COMPONENTS FOR MAINTENANCE.



Wash optimisation

The wash optimisation feature eliminates the need for the half load option. Wash optimisation is achieved by intelligent technology that allows the programme setting, water levels and energy consumption to be automatically adjusted according to the weight and nature of the load.



30° Quickwash

A quick wash programme is offered on some of the laundry products, suitable for mixed materials, up to a maximum of 2.5Kg of dry clothes. On the 50's style washer this programme is called Daily 30°C.



Electronic controls

The latest Smeg laundry products include an LED on the front panel, which shows the time to the end of the programme and the spin speed selected. The washing machine panels illustrated show the three option buttons for the rapid cycle, easy iron and delay timer.



On the WDF16BAX1 the drying button takes the place of the rapid cycle button and two smaller buttons show the drying temperature selected.



50's style washing machines

Inspired by the distinctive FAB refrigeration range, the retro washing machines are now available in a choice of four colours, designed to co-ordinate with other retro appliances.

They incorporate a colour co-ordinating front door so that the porthole door and controls can be hidden from view.

These washing machines are AAA rated, have a 1600rpm spin speed and a choice of 15 wash programmes.

The door encompasses soft round curves that are redolent of 1950's design, a stylish handle and the characteristic Smeg logo.

For the first time it is not simply an appliance useful for doing the chores, but is also an inspirational piece of kitchen furniture, combining practicality with technology and grace.

Energy		Washing machine
Manufacturer		WMFAB16
MODEL		
More efficient		
Less efficient		
Energy Consumption kWh/cycle <small>(based on standard test results for 60°C cotton cycle)</small> <small>Actual consumption will depend on how the appliance is used.</small>		0.95
Washing Performance <small>A: higher G: lower</small>		A B C D E F G
Spin Drying Performance <small>A: higher G: lower</small> <small>Spin speed (rpm)</small>		A B C D E F G
Capacity (cotton) Kg		5.0
Water Consumption L		47
Further information is contained in product brochures.		

Energy efficiency Class A

All Smeg washing machines are A rated for energy (and washer/dryers are B rated). The more efficient an appliance is the less energy it requires, with A rated products being the most efficient and G being the least. Using models that are A rated for energy efficiency, together with lower than average water consumption not only saves money but is the best for the environment. According to figures from DEFRA a typical washing machine uses 30-100 litres per wash programme, and a washer dryer uses 60-200 litres per wash and dry programme (both are based on a wash load capacity of 5Kg). Smeg washing machines use approx 47 litres and washer dryers use approx 90 litres, making them an efficient and cost effective choice.

Washing performance Class A

The wash performance is the most important characteristic of a washing machine and washer/dryer. Smeg has ensured that every appliance in the laundry range is rated A class for wash performance.

Spin drying performance Class A

Spin drying is also key to the performance of a washing machine and all Smeg washing machines are A rated for spin drying. AAA is only given to appliances which fully comply with the strict parameters set out in the European directives, offering best performance whilst also respecting the environment.

WMFAB16RO

50'S STYLE FREE-STANDING WASHING MACHINE, PINK
ENERGY RATING AAA



WMFAB16P

50'S STYLE FREE-STANDING WASHING MACHINE, CREAM
ENERGY RATING AAA



WMFAB16NE

50'S STYLE FREE-STANDING WASHING MACHINE, BLACK
ENERGY RATING AAA



Electronic display panel
5 buttons: start/pause, rapid wash, easy iron, delay timer, spin
On/off & Programme control
Door opening release
Storage area in outer door

15 washing programmes, including 30°C
Daily 2.5Kg quick wash, plus 3 options:
rapid wash, easy iron, delay timer
Variable spin speed up to 1600 rpm
Max 5Kg of dry laundry
St/steel drum and tank
Extra large 300mm porthole
Colour co-ordinating front door
Door safety lock
Automatic variable load
Self cleaning pump & filter
Adjustable feet
Total Aquastop

CONSUMPTION:
Water: 47 litres
Energy: 0.95kW/h
Nominal power: 2.00kW

Energy efficiency class: A
Washing performance: A
Spin Drying performance: A

AVAILABLE IN THE FOLLOWING VERSIONS:

Pink **WMFAB16RO**
Cream **WMFAB16P**
Black **WMFAB16NE**
Pastel blue **WMFAB16AZ**

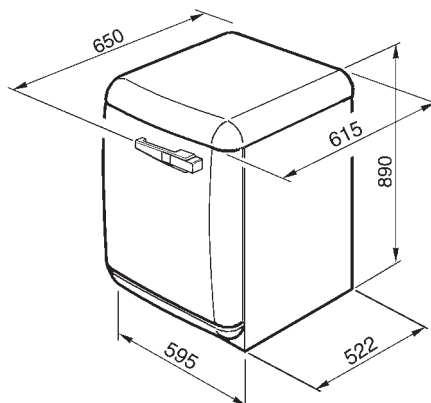

NB: This washing machine will not fit under a standard work top. Please check measurements carefully.



WMFAB16AZ



WMF16AX1

WMF16AX1

FREE-STANDING WASHING MACHINE,
FULLY CLAD IN ST/STEEL
ENERGY RATING AAA



Electronic display panel
5 buttons: start/pause, rapid wash, easy iron, delay timer, spin
On/off & Programme control
Door opening release

15 washing programmes including Quickwash at 30°C, plus 3 options: rapid wash, easy iron, delay timer
Variable spin speed up to 1600 rpm
Delay timer
Max 5Kg of dry laundry
St/steel drum and tank
Extra large 300mm porthole
Door safety lock
Automatic variable load
Self cleaning pump & filter
Adjustable feet
Total Aquastop

CONSUMPTION:
Water: 47 litres
Energy: 0.95kW/h
Nominal power: 2.00kW

Energy efficiency class: A
Washing performance: A
Spin Drying performance: A

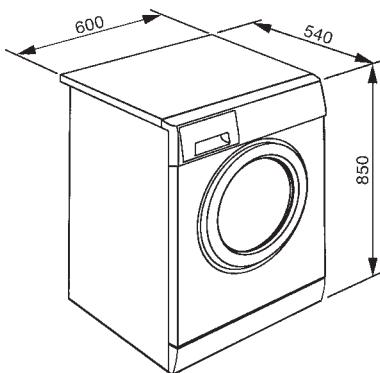

WDF16BAX1

FREE-STANDING WASHER/DRYER,
FULLY CLAD IN ST/STEEL
ENERGY RATING BA



Electronic display panel
5 buttons: start/pause, easy iron, delay timer, drying, spin
On/off & Programme control
Door opening release

14 washing programmes, including Quickwash at 30°C, plus 3 options: easy iron, delay timer, drying
Variable spin speed up to 1600 rpm
Humidity sensor that automatically calculates dry time
Max washing capacity: 5Kg dry laundry
Max drying capacity: 2.5Kg
Condenser drying
St/steel drum and tank
Extra large 300mm porthole
Door safety lock
Automatic variable load
Self cleaning pump & filter
Adjustable feet
Total Aquastop

CONSUMPTION:
For washing only: water: 47 litres, energy: 0.95kW/h
For complete 5Kg wash + 2 sessions of 2.5Kg drying:
Water 90 litres, energy: 4.05kW/h
Nominal power: 2.00kW

Energy efficiency class: B
Washing performance: A

WMF16A1

FREE-STANDING WASHING MACHINE,
WHITE
ENERGY RATING AAA



Electronic display panel
5 buttons: start/pause, rapid wash, easy iron, delay timer, spin
On/off & Programme control
Door opening release

15 washing programmes including Quickwash at 30°C, plus 3 options: rapid wash, easy iron, delay timer
Variable spin speed up to 1600 rpm
Max 5Kg of dry laundry
St/steel drum and tank
Extra large 300mm porthole
Door safety lock
Automatic variable load
Self cleaning pump & filter
Adjustable feet
Total Aquastop

CONSUMPTION:
Water: 47 litres
Energy: 0.95kW/h
Nominal power: 2.00kW

Energy efficiency class: A
Washing performance: A
Spin Drying performance: A



WDF16BA1

FREE-STANDING WASHER/DRYER,
WHITE
ENERGY RATING BA



Electronic display panel
5 buttons: start/pause, rapid wash, easy iron, drying, spin
On/off & Programme control
Door opening release

14 washing programmes including Quickwash at 30°C, plus 3 options: rapid wash, delay timer, drying
Variable spin speed up to 1600 rpm
Humidity sensor that automatically calculates dry time
Max washing capacity: 5Kg dry laundry
Max drying capacity: 2.5Kg
Condenser drying
St/steel drum and tank
Extra large 300mm porthole
Door safety lock
Automatic variable load
Self cleaning pump & filter
Adjustable feet
Total Aquastop

CONSUMPTION:
For washing only: water: 47 litres, energy: 0.95kW/h
For complete 5Kg wash + 2 sessions of 2.5Kg drying:
Water 90 litres, energy: 4.05kW/h
Nominal power: 2.00kW

Energy efficiency class: B
Washing performance: A

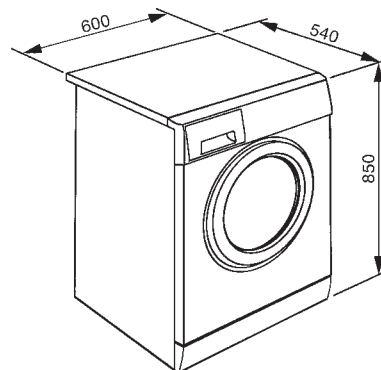

WMI16AAA1

FULLY INTEGRATED WASHING MACHINE
ENERGY RATING AAA



Electronic display panel
5 buttons: start/pause, rapid wash, easy iron, half load, spin
On/off & Programme control
Door opening release

15 washing programmes including Quickwash at 30°C, plus 3 options: rapid wash, easy iron and delay timer
Variable spin speed up to 1600 rpm
Max 5Kg of dry laundry
St/steel drum and tank
Extra large 300mm porthole
Door safety lock
Automatic variable load
Self cleaning pump & filter
Furniture door can be hinged left or right
Adjustable feet
Total aquastop

CONSUMPTION:
Water: 47 litres
Energy: 0.95kW/h
Nominal power: 2.00kW

Energy efficiency class: A
Washing performance: A
Spin Drying performance: A

WDI16BA1

FULLY INTEGRATED WASHER/DRYER
ENERGY RATING BA



Electronic display panel
5 buttons: start/pause, rapid wash, easy iron, drying, spin
On/off & Programme control
Door opening release

14 washing programmes including Quickwash at 30°C, plus 3 options: rapid wash, delay timer, drying
Variable spin speed up to 1600 rpm
Humidity sensor that automatically calculates dry time
Max washing capacity: 5Kg dry laundry
Max drying capacity: 2.5Kg
Condenser drying
St/steel drum and tank
Extra large 300mm porthole
Door safety lock
Automatic variable load
Self cleaning pump & filter
Furniture door can be hinged left or right
Adjustable feet
Total aquastop

CONSUMPTION:
For washing only: water: 47 litres, energy: 0.95kW/h
For complete 5Kg wash + 2 sessions of 2.5Kg drying:
Water 90 litres, energy: 4.05kW/h
Nominal power: 2.00kW

Energy efficiency class: B
Washing performance: A

